

ENERPAC®

HEAVY LIFTING TECHNOLOGY®

EMPOWERING YOUR SUCCESS

Instruction- and Maintenance Manual

Strand dispenser

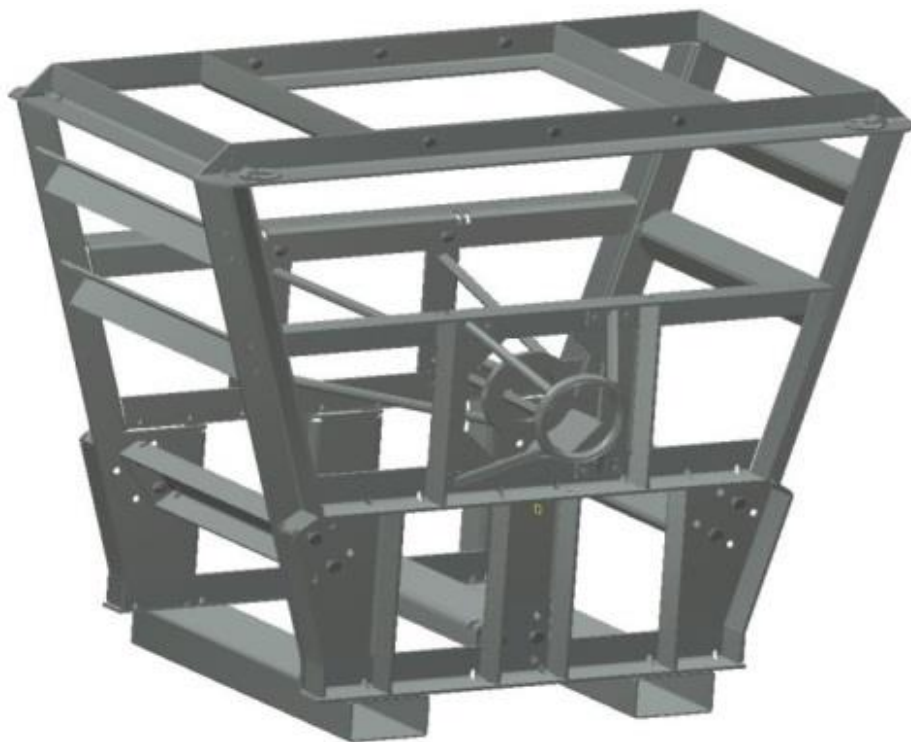

Document ID: ED.03103.00.001.R00.ENG
Original instructions (Untranslated edition)

Enerpac Heavy Lifting Technology BV. Spinelstraat 15, P.O. Box 421, 7554 TW Hengelo, the Netherlands

Revisions

Rev	Description	Date	Author	Checked	Approved by
00	Initial version	17 July '17	D. Rosier		R. Broenink

Preface

Dear customer,

This is the manual for assembling, operating and maintaining your Strand dispenser.

The manual is part of the handbook of the System; see Ref [2] “Handbook of the System”, and is meant to be used by operators and by maintenance engineers.



It is essential that the user reads this manual completely **before** start working with the System.

- All information, illustrations and technical data in this manual are applicable to the System as it was at the **time of issuing** of this manual.
- We continuously **improve** our products and therefore reserve the right to implement improvements and **changes** whenever it is necessary and possible to do so, without any obligation to apply improvements or changes to models purchased previously. Nevertheless, when the system is improved due to serious **safety issues**, you as a customer will be informed.
- If this manual becomes **unreadable**, in whole or in part, you can order a copy by providing us the number given on the front cover.
- Despite the fact that this manual has been drafted with great care, we **cannot guarantee** that it does not contain any errors.
- The use and interpretation of all information in this manual and the possible consequences through improper use of the system are wholly the **responsibility of the user**. Enerpac shall under no circumstances accept any responsibility for such improper use.

Pictures and illustrations in this manual may differ from reality.

Within this document use is made of **structured text**. The following conventions are applied:

- Procedural steps are numbered. Execute the steps sequentially. Do not skip any step.
- Responses of the system are written on the next line in italic font.
- Choices are indicated with bullets.

Example:

1. Press the button
The indicator turns green
2. Click on the square icon
The system starts moving
3. Select one of the following options:
 - Click the red icon for lifting
 - Click the green icon for lowering
 - Click the blue icon for ending the operation

© All rights reserved. Nothing in this publication may be duplicated, stored in an automated database or made public in any form or in any manner, whether electronic, mechanical, by photocopying, recording or any other means, without prior written approval by Enerpac.
--

We hope this manual will help you to use the System properly.
Enerpac.

Contents

- Preface** _____ **3**
- Contents** _____ **4**
- 1. Introduction** _____ **5**
 - 1.1. Manufacturer address** _____ **5**
 - 1.2. Declaration** _____ **5**
 - 1.3. Referenced documents** _____ **5**
 - 1.4. Identification** _____ **5**
 - 1.5. Liability** _____ **6**
 - 1.6. Intended use** _____ **6**
 - 1.7. Modifications** _____ **6**
 - 1.8. Personnel and responsibilities** _____ **7**
 - 1.9. Lifetime** _____ **10**
 - 1.10. Warning symbols used within this document** _____ **11**
- 2. General safety aspects** _____ **12**
 - 2.1. Mandatory protective gear** _____ **12**
 - 2.2. General safety regulations** _____ **12**
 - 2.3. Symbols applied to the System** _____ **13**
 - 2.4. Welding work** _____ **14**
 - 2.5. Assembly and disassembly** _____ **15**
 - 2.6. Transport, loading and unloading of the System** _____ **15**
- 3. System Overview** _____ **16**
 - 3.1. General** _____ **16**
 - 3.2. How to use the strand dispenser** _____ **17**
 - 3.3. Drawings** _____ **21**

1. Introduction

1.1. Manufacturer address

Enerpac Heavy Lifting Technology B.V
Spinelstraat 15, 7554 TS
Hengelo
The Netherlands
Tel. +31 74 242 20 45
Fax. +31 74 243 03 38
Email: info.hengelo@enerpac.com
Website: www.enerpac.com

1.2. Declaration

Declaration of Conformity according to machine Directive 2006/42/EC.

1.3. Referenced documents

Ref	Name	Identification	Manufacturer
1.	General rules and safety requirements for systems and their components	NEN-EN-ISO 4413	NEN
2.	Handbook of the System		Enerpac
3.	EC Declaration of conformity		Enerpac
4.	ASME B30.1-2015	Jacks, Industrial Rollers, Air Casters and Hydraulic Gantries. (Safety Standard for Cableways, Cranes, Derricks, Hoists, Hooks, Jacks and Slings)	American Society of Mechanical Engineers

1.4. Identification

Each main component is fitted with a name plate as shown below.

Type

Drawing Rev.

Order nr.

Machinery part of

Description

Year of manufacture

Self weight

Enerpac Heavy Lifting Technology B.V.
Spinelstraat 15 7554 TW Hengelo - Holland +31(0)74 24 22 045



The name plates are official documents. It is not permitted to alter them or render them illegible.

1.5. Liability

- Personnel as well as other people involved in the usage of the System are expected to have read and **understood** this manual.
- In cases of **doubt** about the use or application of this machine, always contact Enerpac for advice and recommendations.
- **Unauthorised alterations** to the machine may have a deleterious effect on the characteristics of the machine and may disrupt the control functions. Unauthorised alterations therefore annul any resultant damage claims against the manufacturer.
- The **risk analysis** conducted by Enerpac, intended usage and reasonably foreseeable incorrect usage of the System were assessed. The instructions in this manual were drawn up based on this analysis.

1.6. Intended use

The System is intended to contain a coiled strand.

The definition of 'intended use' excludes any and all uses which do not meet the descriptions, including use that exceeds the machine's technical limitations. The manufacturer shall not accept any liability for damage resulting from use that is not in accordance with the machine's intended use. The user shall bear any and all risks. The definition of 'intended use' also includes strict compliance with the instructions in the user manual and assumes that the equipment is inspected and maintained at the indicated times.

- The System should only be used in the **intended manner** as described in the instructions in this manual.
- The System should only be operated by **operators** with full knowledge of the applicable safety regulations and the hazards which may arise during use.
- The System was developed and built according to the officially recognised safety **regulations**. However, if the machine is not used as intended:
 - This may pose a **risk** to the health and lives of operators and bystanders.
 - The System may not function properly or may create **hazardous** situations.
- The System should only be used if the machine is in perfect technical **condition**.
- Faults which may result in hazardous situations must be **resolved** immediately.
- The machine must not be used in potentially **explosive** environments.

1.7. Modifications

Never make any **modifications** or additions which could have an adverse impact on safety without prior approval from the manufacturer. This also applies to the installation and adjustment of safety devices and valves and welding work on the System.

Spare parts must always meet the technical specifications given by Enerpac in the construction file and the component construction lists for the machine. It is recommended to use original spare parts. In cases of doubt, please contact Enerpac.

1.8. Personnel and responsibilities

- Only **qualified personnel** are allowed to **operate** the System. Qualified personnel are those who have followed the official Gantry training of Enerpac and have obtained the Certificate.
- Only **qualified personnel** are allowed to **maintain** the System. Qualified personnel are those who have certified main education for the jobs they have perform.
- **Qualification** of the personnel is a responsibility of the customer.
- Always comply with legal **minimum age** stipulations.
- The System should only be used, maintained and repaired by properly **instructed** and **trained** personnel. Clearly describe the qualifications of the relevant employees with regard to use, commissioning, assembly, disassembly and all maintenance and repair work. If must be performed by third parties, they must receive clear instructions so both the client and the contractor are up-to-date on the agreements reached.
- The supervisor and operator are authorized to refrain from following any instructions from **third parties** that may pose a risk to the machines or bystanders.
- Personnel who have **not been fully trained** and instructed in the use of the machine, or personnel who have only received general training, may only perform work on the System under continuous **supervision** of a qualified person.
- **Assembly and disassembly** may only be performed by trained installers under the supervision of an authorized person who has adequate knowledge of the System.

The responsibilities listed below are in accordance with the standard as referred to in Ref [4] "ASME B30.1-2015".

- In some situations, the owner and the user may be the same entity and is therefore accountable for all of the following responsibilities a listed in this chapter.
- In other cases, the user may lease or rent the system from the system without supervisory, operational, maintenance, support personnel, or services from the system owner. In these situations, sections 1.8.1 and 1.8.2. apply.

1.8.1. The owner of the system

The responsibilities of the owner of the system are:

- a) make sure the system meets the requirements as given in this manual as well as specific job requirements defined by the user.
- b) make sure the system and all necessary components, specified by the manufacturer, meet the user's requested configuration and capacity.
- c) providing the applicable capacity charts to the user
- d) providing this manual to the user to enable correct assembly, disassembly, operation and maintenance information
- e) make sure all inspections and maintenance activities are performed.
- f) designating personnel for maintenance, repair, transport, assembly, and disassembly.
- g) designating personnel for inspections as required in the applicable chapters.

1.8.2. The user of the system

The responsibilities of the user of the system are:

- a) complying with the requirements of this manual and all regulations applicable at the work site.
- b) using supervisors for activities
- c) ensure that the system is in proper operating condition, prior to initial use at the worksite by
 - verifying that the Owner has provided this manual
 - verifying that a frequent inspection has been performed

- d) verifying that the system has the necessary capacity to perform the proposed operations in the planned configuration
- e) ensuring the assigned operators have been notified of adjustments or repairs that have not yet been completed, prior to commencing operations
- f) designating personnel for inspections as required in the applicable chapter
- g) designating personnel for maintenance, repair, transport, assembly, and disassembly
- h) ensuring that all personnel involved in maintenance, repair, transport, assembly, disassembly, and inspection are aware of their responsibilities, assigned duties, and the associated hazards
- i) ensuring that the inspection, testing, and maintenance programs specified by owner are followed

1.8.3. The site supervisor

In some cases the site supervisor and the system director may be the same person.

The responsibilities of the site supervisor shall include the following:

- j) ensuring that the system meets the requirements prior to initial site usage.
- k) determining if additional regulations or requirements are applicable.
- l) ensuring that a qualified person is designated as the system director.
- m) ensuring that the operations are coordinated with other jobsite activities that will be affected by or will affect the operations.
- n) ensuring that the area for the system is adequately prepared. The preparation includes, but is not limited to, the following:
 1. access for the system and associated equipment.
 2. sufficient room to assemble and disassemble the system.
 3. an operating area that is suitable for the system with respect to levelness, surface conditions, support capability, proximity to power lines, excavations, slopes, underground utilities, subsurface construction, and obstructions to operation.
 4. traffic control as necessary to restrict unauthorized access to the system's working area.
 5. ensuring that work involving the assembly and disassembly of system is supervised by a qualified person .
 6. ensuring that operators meet the physical, knowledge, and skill requirements as described in this manual.
 7. ensuring that conditions that may adversely affect the operations are addressed. Such conditions include, but are not limited to, the following:
 - poor soil or support conditions
 - wind velocity or gusting winds
 - weather conditions
 - extreme temperatures
 - inadequate lighting
 - operating surface conditions
 - excessive noise proximity to energized sources (e.g., power lines, pressurized lines)
 - ensuring that work performed by the rigging crew is supervised by a qualified person
 - ensuring that maintenance is performed by a designated person

1.8.4. The system director

The system Director's responsibilities shall include the following:

- a) being present at the job site during the operations.
- b) stopping the operations if alerted to an unsafe condition.
- c) ensuring that the preparation of the area needed to support the operation has been completed before the operation starts.

- d) ensuring necessary traffic controls are in place to restrict unauthorized access to the system's work area.
- e) ensuring that personnel involved in the operations understand their responsibilities, assigned duties, and the associated hazards.
- f) addressing safety concerns raised by the system operator or other personnel and being responsible if he decides to overrule those concerns and directs the operation to continue. In all cases the manufacturer's criteria for safe operation and the requirements of this manual shall be followed.
- g) designating the signal person(s) and conveying that information to the system operator.
- h) evaluating the operation in proximity to energized sources.
- i) ensuring precautions are implemented when hazards associated with special load handling operations are present. Such operations may include, but are not limited to, the following:
 - multiple types of system used simultaneously
 - shifting centre(s) of gravity or lifting below the centre of gravity
 - shifting, inclined, or moving surfaces
 - operating barges
- j) informing the system operator of the weight and planned movement of the loads to be handled.
- k) obtaining the system operator's verification that this weight does not exceed the system's rated load.
- l) ensuring that load rigging personnel have been designated for the system.
- m) ensuring that the load is properly rigged and stable.

1.8.5. The operators

The system Operator shall be responsible for the following listed items.

The system Operator shall not be responsible for hazards or conditions that are not under his direct control and that adversely affect the system operations.

Whenever the system Operator has doubt as to the safety of operation, the system Operator shall stop the system functions in a controlled manner. System operations shall resume only after safety concerns have been addressed and the continuation of the operation is directed by the system Director.

The system Operator's responsibilities shall include the following:

- a) reviewing the requirements for the system with the Director before the operations.
- b) knowing what types of site conditions could adversely affect the operation of the system and consulting with the system Director concerning the possible presence of those conditions.
- c) understanding and applying the information contained in this manual.
- d) understanding the system's functions and limitations as well as its particular operating characteristics.
- e) using the system's load/capacity chart(s) and diagrams and applying all notes and warnings related to the charts to confirm the correct system configuration to suit the load, site, and load handling conditions.
- f) refusing to operate the system when any portion of the load or the system could be adversely affected by proximity to energized sources until evaluated and approved by a qualified person.
- g) performing inspections as specified in the applicable chapter.
- h) promptly reporting the need for any adjustments or repairs.
- i) following applicable lock out/tag out procedures,
- j) not operating the system when physically or mentally unfit.
- k) ensuring that all controls are in the off or neutral position and that all personnel are in the clear before energizing the system.
- l) not engaging in any practice that will divert his attention while actually operating the system controls.
- m) testing the system function controls that will be used and operating the system only if those function controls respond properly.

- n) operating the system's functions, under normal operating conditions, in a smooth and controlled manner.
- o) knowing and following the procedures specified by the system manufacturer or approved by a qualified person for assembly, disassembly, and setting up the system.
- p) knowing how to travel the system, if applicable.
- q) ensuring that the load and rigging weight(s) have been provided.
- r) calculating or determining the rated load for all configurations that will be used and verifying, using the capacity chart(s), that the system has sufficient capacity for the proposed operation.
- s) considering all factors known that might affect the system capacity and informing the system Director of the need to make appropriate adjustments.
- t) knowing the standard and special signals as specified in the applicable chapter and responding to such signals from the signalperson. When a signalperson is not required, the system Operator is then responsible for the movement of the system. However, the system Operator shall obey a stop signal at all times, no matter who gives it.
- u) understanding bask load rigging procedures. For responsibility of rigging the load and ensuring that the load is rigged properly
- v) if power fails during the operations
 - set all locking devices
 - move all power controls to the OFF or neutral position
 - secure and stabilize the load, if practical
- w) before leaving the system unattended
 - secure and stabilize the load
 - set all locking devices
 - put the system controls in the OFF or neutral position
 - turn off the system power source
 - follow the recommendations as given in this manual or given by a qualified person for securing the system

1.9. Lifetime

The safe and effective lifetime of the System strongly depends on

- the intensity of the use
- the quality of the maintenance

1.10. Warning symbols used within this document

This manual uses warnings and symbols to draw your attention to important safety information. The table below indicate the most common used labels in industrial documents



NB

'NB' is used to highlight important **work activities** and for **additional information**



Caution

'Caution' is used if failure to heed the given instructions may result in **damage to the system**.



Attention

General warning to the operator of potential damage to **equipment** and the **environment**.



Hazard

Draws the user's attention to potential **hazards to personnel** if work instructions are not followed precisely.

2. General safety aspects

Subjects that must be followed are covered not only in this chapter; also in other chapters are specific safety directions that must be read and followed.

2.1. Mandatory protective gear

While using the System ensure that the applicable safety regulations are observed.

Make sure that all people on the working place observe the following safety regulations:



Always wear • safety goggles
and a safety helmet



Always wear • safety footwear



Wear safety gloves.
But we strongly advise not to wear them when
operating handheld control consoles



Wear a safety harness when working at heights
more than 2 meters

2.2. General safety regulations

Special safety regulations are given in the relevant national legislations or company regulations for accident prevention. Compliance with these rules and regulations is a legal requirement and a condition of employment. In addition to the safety regulations set out under the law, also observe the following points:

- Keep the worksite **clean**.
- Before every start-up, always check that there are no **persons** in an unsafe situation or position with respect to the System. Stop working if, despite warnings, there are still employees in an unsafe situation.
- Only use the System on an adequately stable and robust **subsurface**.
- Keep all equipment out of the area of above-ground **power lines**.
- The **coverings** must be closed (this does not apply to the covering on control panels).
- The operator must switch off the System before leaving it **unattended**.
- Use all required **Personal Protection** Equipment (PPE).
- Do not wear any loose **clothing or jewelry**. Long hair must be tied back.
- **Tools** and equipment, necessary for (dis-)assembly of the System, as well as for maintenance has to be in good condition. Badly maintained equipment can cause time wastage and lead to permanent damage to the equipment and/or its surroundings.

- Keep the moving equipment of the System **clean** to prevent it from jamming or causing damage to itself or other equipment.
- Do not use the System, whether loaded or not, while unauthorized people are in its **vicinity**. The System can be operated remotely.
- Maintain **focus** during the work. Carelessness may result in serious injuries.
- Additional **lifting gear** and accessories such as hawsers, shackles, lugs, slings etc. must comply with the legal requirements imposed in the country of use.
- **Inspect** the condition of the System before every individual start-up, given the fact that the slightest defect may have severe consequences.

Enerpac is not liable for improper use of accessories in combination with the System.

2.3. Symbols applied to the System

The System is labelled with

- warning symbols
- symbols with mandatory directions.

The tables below explain the most common used **warning symbols**:



Danger of contact with moving machine parts



Danger
Lethal voltage in the control panels



Danger of **parts of hands** getting trapped/caught



Danger of **parts of feet** getting trapped/caught



Danger of **falling**



Danger
Exercise extreme attention and caution when **under moving loads**.



Danger of getting **trapped**/caught between moving parts.

The table below shows the most commonly symbols with **mandatory directions** in industrial environments:



Read the instructions/instruction manual before operation.



Wear **gloves** to prevent injury from and/or exposure to chemicals.



Wear safety **glasses** to prevent eye injuries.



Wear safety **shoes** to prevent injuries caused by falling objects and/or feet getting caught in machinery.



Wear **hearing** protection.



Wear a safety **helmet** to prevent injuries caused by falling objects.



Wear a safety **harness**



The stickers on the machine are **official documents** and it is not permitted to alter them or render them illegible.



It is **strictly obligatory** to observe the warning symbols and the mandatory symbols applied to the machine and to keep them in fully legible condition.

2.4. Welding work

- Welding, cutting and grinding work on the System is only permitted with the **prior written consent** of the manufacturer.
- Welders must be properly qualified and must have a valid welding certificate.
- If welding work needs to be performed on the System then
 - Switch the machine off
 - Disconnect all power cables and communications cables
 - Connect the system to a direct earth line.



Welding, cutting or grinding work on the System is not permitted without the manufacturer's prior written permission.

2.5. Assembly and disassembly

- **Assembly** and disassembly of the System has to be performed by properly trained operators
- Only use **certified lifting** and hoisting equipment.
Check the validity of these certificates and qualifications.
- Only use lifting and hoisting equipment with **suitable capacity** for the loads in question.
- Before commissioning, any parts that were disassembled for transport must be **re-assembled**, re-installed, checked and approved by personnel which is trained and qualified for the job.
- Make sure that the **instructions in this manual** have been followed precisely before commissioning the System.
- Lift loads as described in the user manual (connection points for lifting hooks) and observe the professional standards.



Hazard

Any components that are blocked or stuck in any way (and any parts connected to these components) will be under mechanical tension. If you release these parts, they could change position suddenly and injure you (seriously).

2.6. Transport, loading and unloading of the System

- **Loading** and unloading has to be performed by properly trained operators
- Only use lifting and hoisting equipment with **suitable capacity** for the loads in question.
- **Lift loads** as described in the user manual (connection points for lifting hooks) and observe the professional standards.
- Only use **suitable containers** with adequate load-bearing capacity for transport purposes.
- **Secure** the load properly using suitable connection points and twist locks (for the containers). When using twist locks secure them properly and check that the locking mechanism is working correct.
- To avoid damage during transport, **use timbers**, gummies and plastic packaging to prevent this.
- **Containers** may be used for transport, since they provide rigid protection against and avoid weather influences. Make sure that all parts are secured against sliding around.

3. System Overview

This chapter describes the main functions and components of the strand dispenser.

3.1. General

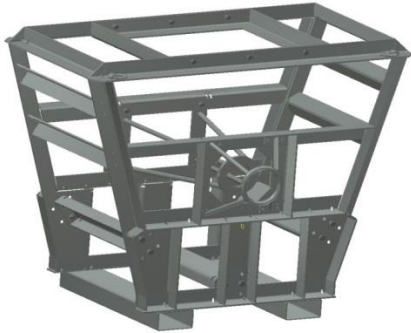

Strands are delivered in a coil. The coil is wrapped with steel bands since a lot of mechanical energy is stored in the coil. Once the coil is put in the strand dispenser, the bands can be cut and the strand can be retrieved in a safe and controlled way.



Coil

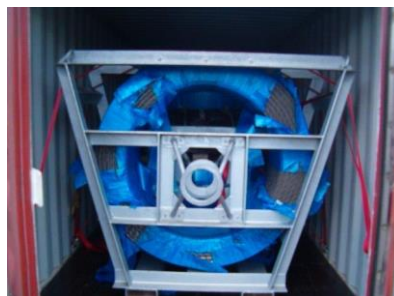

Dispenser with coil

The strand dispenser is an element of strand jack system which consists of the following main parts:



Strand jack



Palm tree

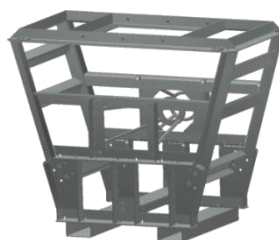

Strand dispenser



Recoiler

3.2. How to use the strand dispenser





Follow the directions as given in this section carefully







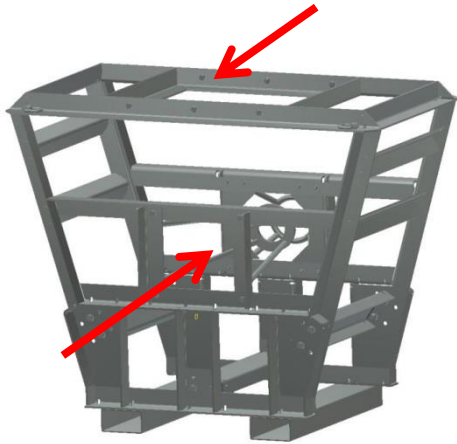
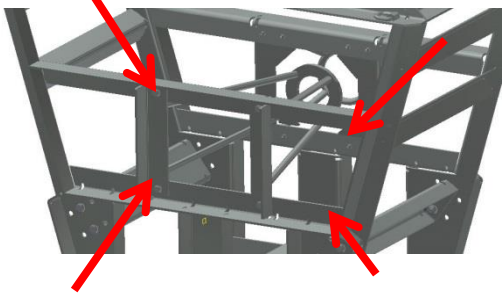



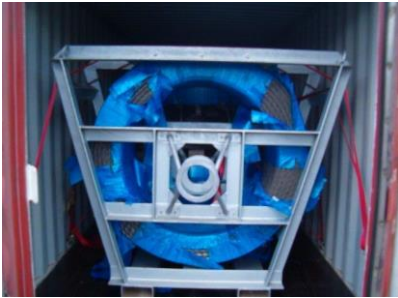

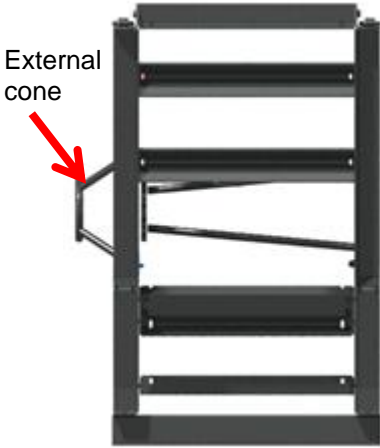

Hazard



- Due to mechanical energy stored in the coil, unpacking without applying the strand dispenser may lead to uncontrolled movements of the coil, causing personal injury to people.
- Not properly applying the strand dispenser may cause injury to people.

Apply the strand dispenser as follows:

<p>1. Open the cone in the middle of the strand dispenser and the frame on top of the dispenser.</p>	
<p>2. Disassemble the four bolts of the cone. Then take the cone out of the dispenser</p>	
<p>3. Remove the 6 bolts of the top frame. Then remove the top frame from the dispenser.</p>	

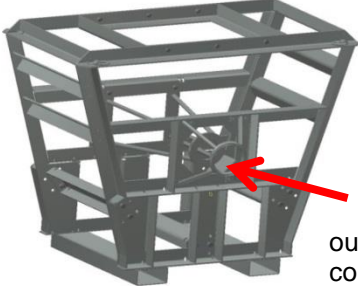
<p>4. Put the coil in the strand dispenser.</p>	
<p>5. Remove the blue packing material of the strand.</p> <p> Attention: do not remove the metal straps</p>	
<p>6. Put the unpacked strand into the strand dispenser.</p> <p>Check the position of the strand: There is a label "FRONT" or "FRONT END".</p> <p>Place this side of the package to external cone of the dispenser.</p> <p> Hazard: wrongly positioning of the coil will cause tangling or bunching-up of the strand</p>	 
<p>7. Assemble the cone to the dispenser.</p> <p>Insert the cone through the centre of the strand coil.</p> <p> Attention: the cone should not touch the inside of the coil. If so, reposition the coil by using different adjustment holes in the frame</p> <p>Make sure all bolts are tightened securely</p>	

8.	<p>Place some wood behind the coil to press the coil strands to the front of the dispenser.</p> <p>The strand windings will stay tightly against each other. This prevents jumping apart of the windings.</p>	 <p>wood</p>
9.	<p>Verify that the strand package is mounted correctly.</p>	
10	<p>Cut the metal straps around the strand coil. Use a large plier. Keep hands clear of coil and dispenser frame when cutting</p> <p> Caution: mind the sharp edges of the banding. Wear gloves</p> <p> Hazard: wrapped strand coils contain stored energy which releases when the straps are cut</p> <p> Hazard: unravelling strand can cause personal injury or even death</p>	<p>straps</p>  
11	<p>Put the starting end of the strand through the outside cone of the strand dispenser. The starting end of the strand is on the inside of the coil.</p> <p>Stored energy will remain in the strand until it becomes straight.</p> <p> Caution: do not stand in front of dispenser cone for stored energy can cause the strand to dispense out.</p>	 <p>outside cone</p>

12	<p>Pull the strand out of the dispenser for the length you require. Enerpac recommends the following procedure:</p> <ul style="list-style-type: none"> • Fastening a DIN 1142 wire rope clamp to the end of the strand. • Put a sling around it • Pull the sling through the outside cone. This can be done by hand or with the use of a fork truck for long pulls. <p> Caution: regardless the method you use, operate carefully!</p>	<p>wire rope clamp</p> 
13	Cut the strand on the required length	
14	<p> Attention: attach the end of the strand which is pointing out of the dispenser securely to the cone. This prevents self-dispensing of the strand</p> <p>Make sure the strand cannot jump out or move during transportation of the dispenser.</p> <p>Keep the unused and open strand coil in the dispenser for safe storage</p>	

3.3. Drawings

